



# ***Swap Hogg Smooth Side Container***

\*Compatible with Swap Hogg and other interchangeable truck body systems



## ***Standard Features:***

- Front, side, & gate panels constructed with 12 GA steel
- Imron® Elite black oven cured paint with epoxy primer (fully primed & painted)
- Floor constructed with 10 GA steel
- Top rails constructed with 3" tubing all around: front, sides, and door(s)
- 3" Structural channel crossmembers spaced 16" on center
- Rear posts constructed with 3/16" steel
- 48" Tall sides (floor to top rail)
- Tapered front & side panels
- Option for single door or barn doors
- Heavy duty door hinges on single door



# Swap Hogg Premium Container

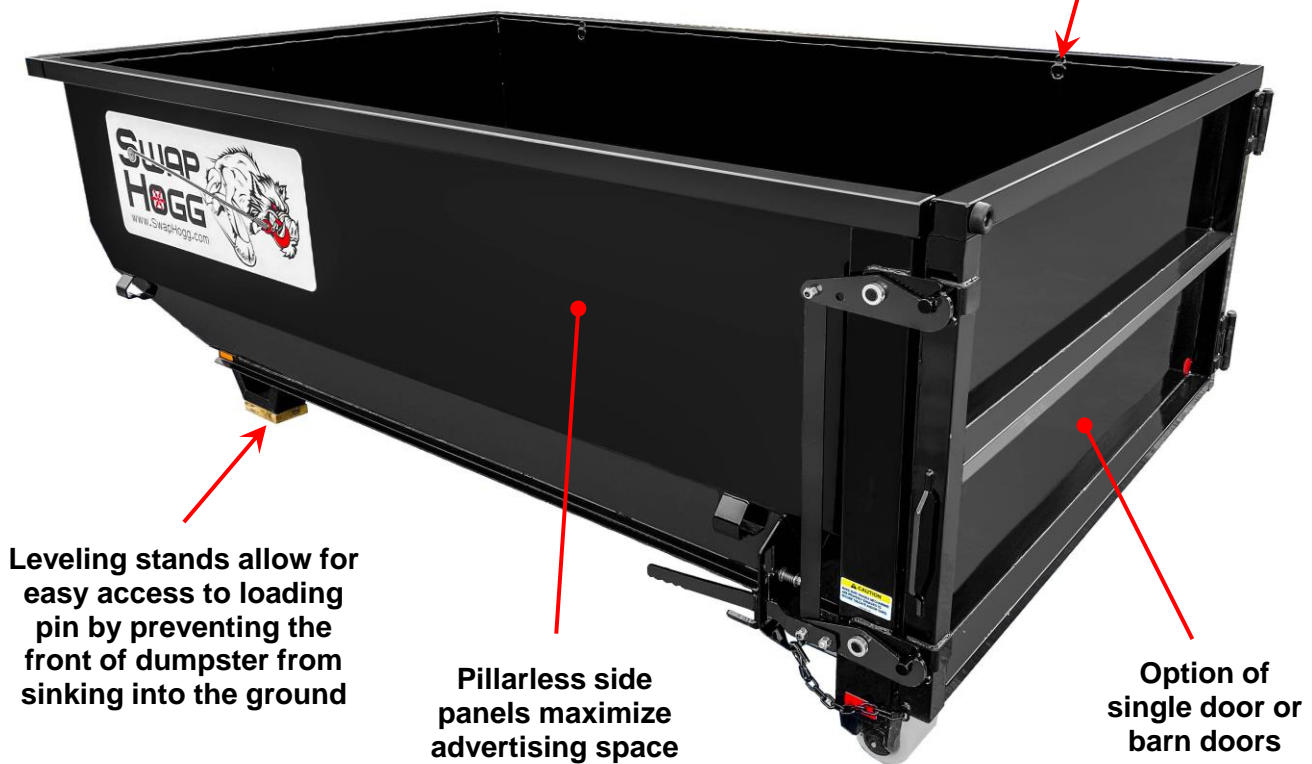
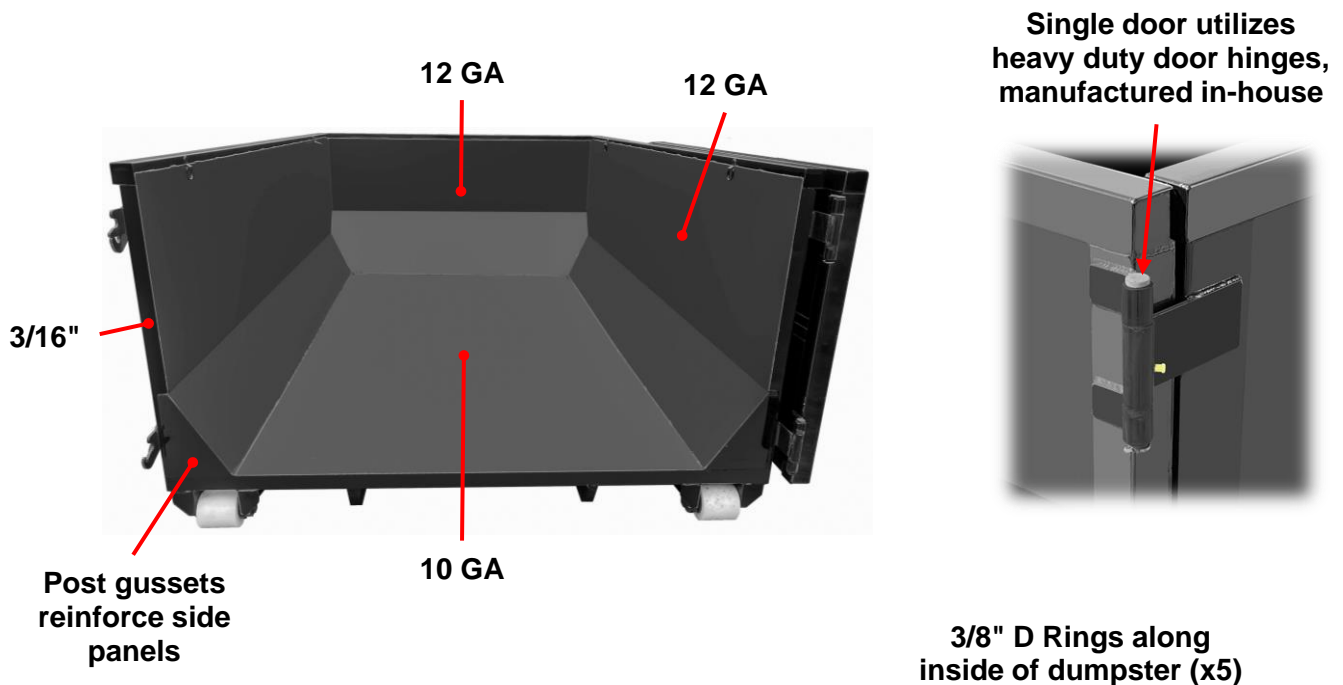

Distributed by:

