

SWAP HOGG



INSTALLATION MANUAL

www.SwapHogg.com

Table of Contents

Safety	2
Warnings	3
System Overview	4
Pre-installation	5
Installation Parts	6
Hoist System Installation	8
➤ Frame	8
➤ Electric	15
➤ Winch Cable	16
Optional Installations	17
➤ Fender Installation	18
➤ Hitch Plate Installation	19
➤ Light Bar Installation	21
Appendix	23
➤ Torque Table	23
➤ Parts & Component List	24
➤ Parts & Component Diagram	25
➤ Troubleshooting	26
➤ Rear Hinge Angle Drill Template	27

Safety



THIS SIGN SHOULD ALERT YOU:

The Society of Automotive Engineers has adopted this SAFETY ALERT SYMBOL to pinpoint characteristics that, if NOT carefully followed, can create a safety hazard. When you see this symbol in this manual or on the machine itself, BE ALERT! Your personal safety and the safety of others is involved.

The purpose of safety symbols is to draw attention to possible dangers. The safety symbols and explanations with them deserve your careful attention. The safety warnings do not by themselves eliminate any danger. The instructions or warnings they give are not substitutes for proper accident prevention procedures.



DANGER

Identifies the most serious hazards.



WARNING

Failure to obey a safety warning can result in injury to yourself and others.



CAUTION

Indicates a hazardous situation which, if not avoided, could result in minor or moderate injury.

Carefully read this manual. Learn how to safely operate the Swap Hogg system and how to use the controls properly. Do not allow anyone to operate the system without proper training and instruction. Unauthorized modification to the Swap Hogg system may impair the function and/or safety of the system.

Follow Safety Instructions

Read all safety messages in the manual and on the Swap Hogg safety labels. Follow recommended precautions and safe operating practice. Maintain all safety labels on the Swap Hogg in good condition. Replaced missing or damaged safety labels with new labels available through your Swap Hogg dealer.

*Always wear safety glasses with side shields when servicing unit. Failure to do this could result in serious injury to the eyes.

*Always disconnect vehicle's battery, prior to installation or repair of equipment.

















*Before attempting any procedure in this book, these safety instructions must be read and understood by all workers who have any part in the preparation or use of this equipment.

*Maximum hydraulic pressure is factory set at 2800 PSI. Tampering with this setting can damage hydraulic components and result in system failure.

*Only use automatic transmission fluid (Dextron III) in the hydraulic reservoir. Check regularly and keep clean.

*Replace any hydraulic component with part compatible with original manufacturer equipment or one that is approved by manufacturer. Replacing with incompatible part will void warranty. Any incompatible part may lead to failure of hoist, which may result in vehicle damage, property damage, injury or death.

Warnings

-  Never exceed the Gross Vehicle Weight Rating of vehicle. Failure to do so may limit the vehicle's handling characteristics. Make certain the load is evenly distributed.
-  Always inspect the area around the vehicle for safe dumping prior to operating the hoist.
-  Operate the hoist only when the vehicle is on a firm, level surface.
-  Do not move the vehicle with the hoist in a raised position.
-  Before raising the hoist, check for adequate overhead clearance. Be alert for overhead electrical wires.
-  Never attempt to work under the body while raised, with material in it.
-  Never attempt to work under the body, without the safety prop rod, in upright position, resting on prop rest, under an UNLOADED body only!
-  Always inspect for defects: broken, worn, or bent parts or weakened areas.
-  Always keep hands, feet, and clothing away from power-driven parts. Remember it is the owner's responsibility to communicate information on safe usage and proper maintenance of all equipment to all users of equipment.
-  Always make sure personnel are clear of areas of danger when using equipment. Maintain 20' distance from all bystanders when operating.
-  Inspect the unit periodically for defects. Parts that are broken, missing, or worn out must be replaced immediately. The unit, or any part of it, can not be altered without prior written permission from the manufacturer.
-  Never operate equipment when under the influence of alcohol, drugs, or medication that might alter your judgment and /or reaction time.
-  Keep hinge pins and bushings well greased. Inspect regularly for proper operation during rotation.
-  Install electrical and hydraulic components AWAY from heat sources and vehicle's exhaust system.
-  NEVER weld any component or bracket to frame of vehicle, before the rear leaf spring hanger. Chassis steel is made from high tensile strength materials and welding to frame may result in voided warranty from manufacturer, increase stress at weld point, cracking due to material fatigue, and damage to other vehicle structure components.
-  If welding is required, for rear of sub frame, or vehicle chassis, ensure all gasoline lines, tanks, fittings, and electrical components are protected from damage, heat and sparks. Failure to protect fuel system may result in gasoline being ignited, which may result in unit, property, or vehicle damage, as well as serious injury or death.

System Overview

The Swap Hogg unit is an electric-over-hydraulic system. The system utilizes an electric winch and hydraulic scissor hoist. Swap Hogg was designed for cab and chassis trucks with a **34" frame width**. Any other frame width will require custom mounting and/or modifications **that the installer is responsible for**. The Swap Hogg unit will come fully assembled to the subframe with the hoist attached (unless ordered otherwise). The winch and hydraulic pump come installed and ready for electrical hook up. Electrical components, mounting brackets, and hardware will be supplied, see *Installation Parts*.

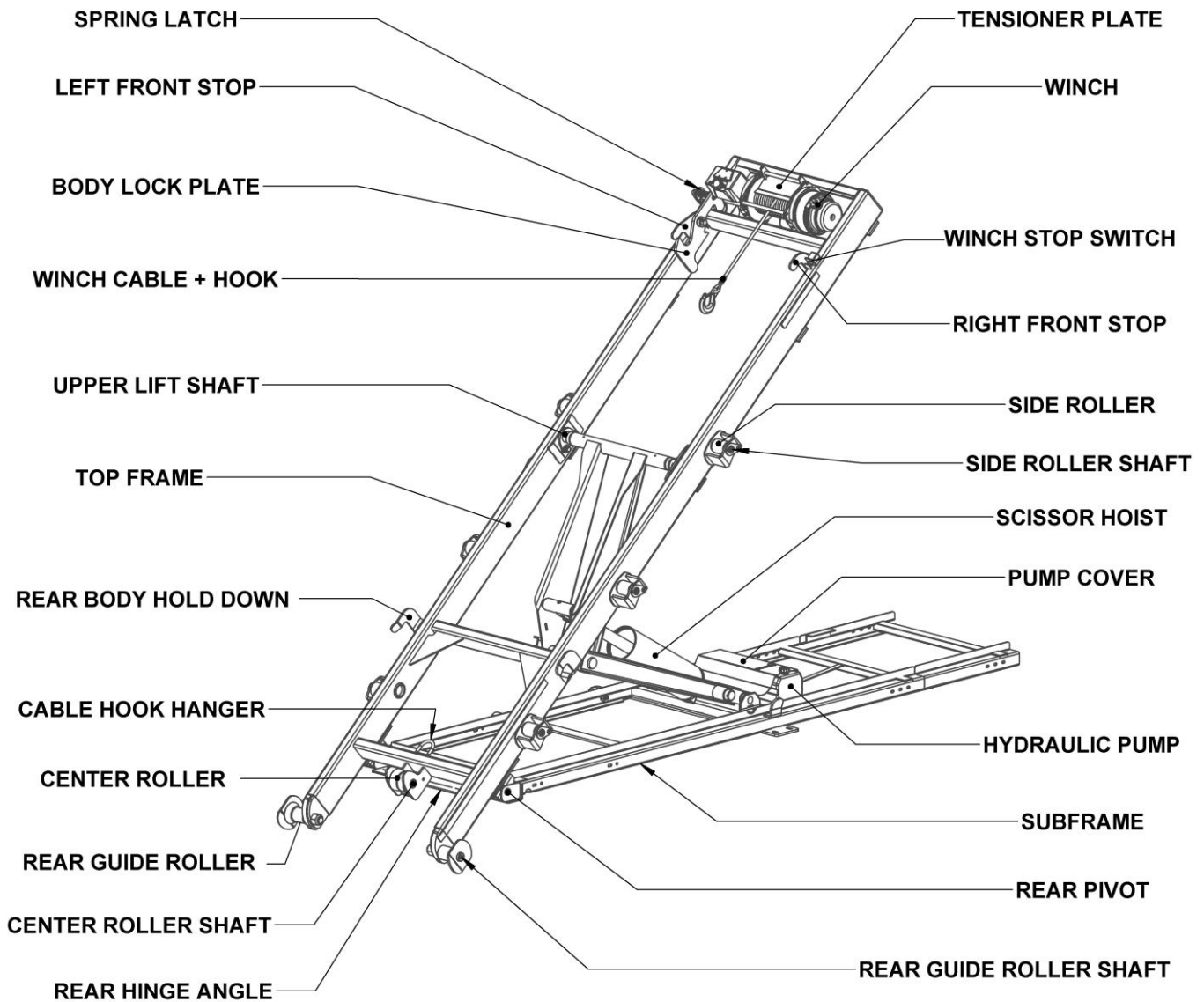

Figure 1-A: Parts Overview

Pre-Installation

The installation will comprise of mounting the Swap Hogg frame to the vehicle chassis frame, as well as running cables to the vehicle's battery and the inside of the vehicle's cab. Read the entire manual carefully to learn the proper procedures for each operation. All information, illustrations and specifications in this manual are based on the latest Swap Hogg information available at the time of publication. The manufacturer reserves the right to make changes and improvements without notice.

Pre-Installation Check List

- Vehicle chassis frame width is 34"
- Vehicle cab to frame end length (CF) is at least 2" longer than the Hoist Length (HL)
*For DESH1512: HL = 10' 10" (130") so the minimum CF length is 11' (132")
- Overhang of 19-1/2" off end of chassis is acceptable
- Vehicle has two 750 CCA batteries
- Vehicle has a heavy duty alternator (150 AMP minimum)

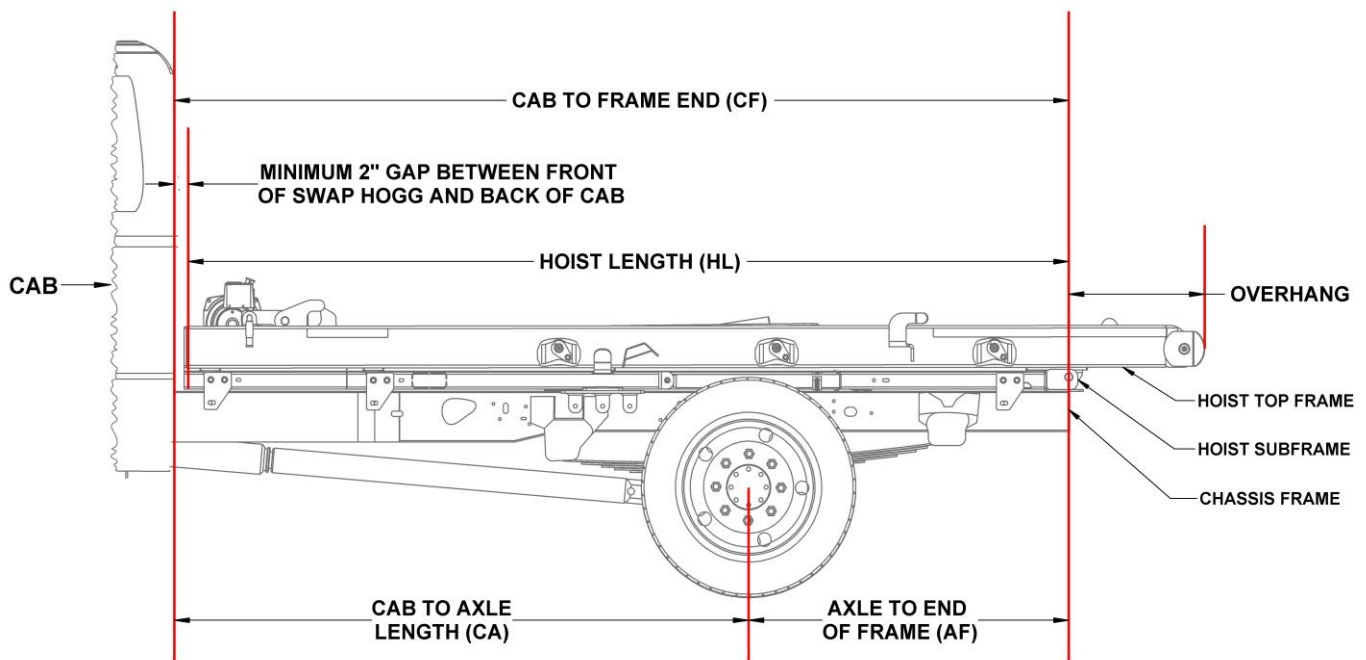

Figure 1-A: Frame Dimensions

Pre-Installation Notes

- *Do not attempt to install on a pickup box removal.
- *Do not weld to vehicle chassis frame anywhere in front of the rear spring hanger.
- *Before beginning installation, make sure top of vehicle chassis is obstruction-free. Ensure all fuel lines, wiring, hoses, and brake lines are protected or covered from sparks or flames.
- *Prior to any drilling through frame, make sure any wiring, gas, or brake lines are clear of drill path.
- *Properly torque all nuts and bolts before using the system, see *Appendix: Torque Table*.

Installation Parts

A *Swap Hogg Installation Kit* is provided with the Swap Hogg unit. The kit contains all necessary installation components for vehicles that meet **all** of the requirements of the *Pre-Installation Checklist*. Additional components may be needed for vehicles that do not meet all of the *Pre-Installation Checklist* requirements.

Swap Hogg Installation Kit

Part Number	Qty.	Description
DEDM444S	2	Rivet Shim
DEDM436	2	Subframe Chassis Bracket
DEDM550	6	Sill Plate
DEDP378	1	Rear Hinge Angle Hardware Kit
	(4)	1/2" - 13 x 1-1/2" Grade 8 Bolt
	(4)	1/2" - 13 Grade 8 Top Lock Nut
	(8)	1/2" Hardened Flat Washer
DEDP202	1	Subframe Chassis Bracket Hardware Kit
	(4)	1/2" - 13 x 2" Grade 8 Bolt
	(4)	1/2" - 13 x 1-1/2" Grade 8 Bolt
	(8)	1/2" - 13 Grade 8 Top Lock Nut
	(16)	1/2" Hardened Flat Washer
DEDP376	3	Sill Plate Hardware Kit
	(2)	1/2" - 13 x 1-1/2" Grade 8 Bolt
	(2)	1/2" - 13 Grade 8 Top Lock Nut
	(4)	1/2" Hardened Flat Washer
	(4)	3/8" - 16 x 1-1/4" Grade 8 Bolt
	(4)	3/8" - 16 Grade 8 Top Lock Nut
	(8)	3/8" Hardened Flat Washer
DEDP426	1	600 Amp Fuse
DEDP428	1	Fuse Holder
DEDP506	1	Fuse to Battery Cable (+)
DEDP416	1	Control Pendant
DEDP418	1	Pendant Connecting Cord (15')
DEDR152	1	Winch Cable (may come factory-installed)
DEDR250	1	Winch Cable Lubricant Spray

*Quantities shown in parenthesis are QUANTITIES PER HARDWARE KIT

Table 1-A

Rear Hinge Angle Hardware Kit (DEDP378)

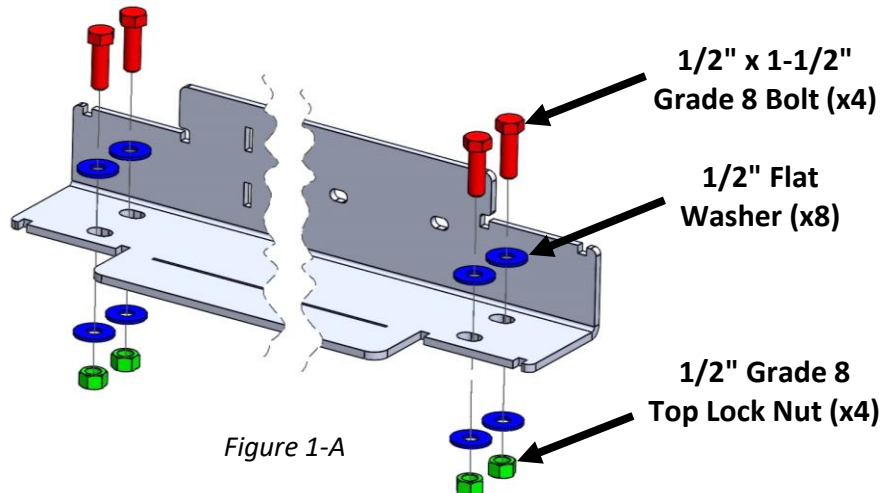

Figure 1-A

Installation Parts

Sill Plate Hardware Kit (DEDP376)

*Sill Plate Hardware Kit
made for a pair (2) of
Sill Plates

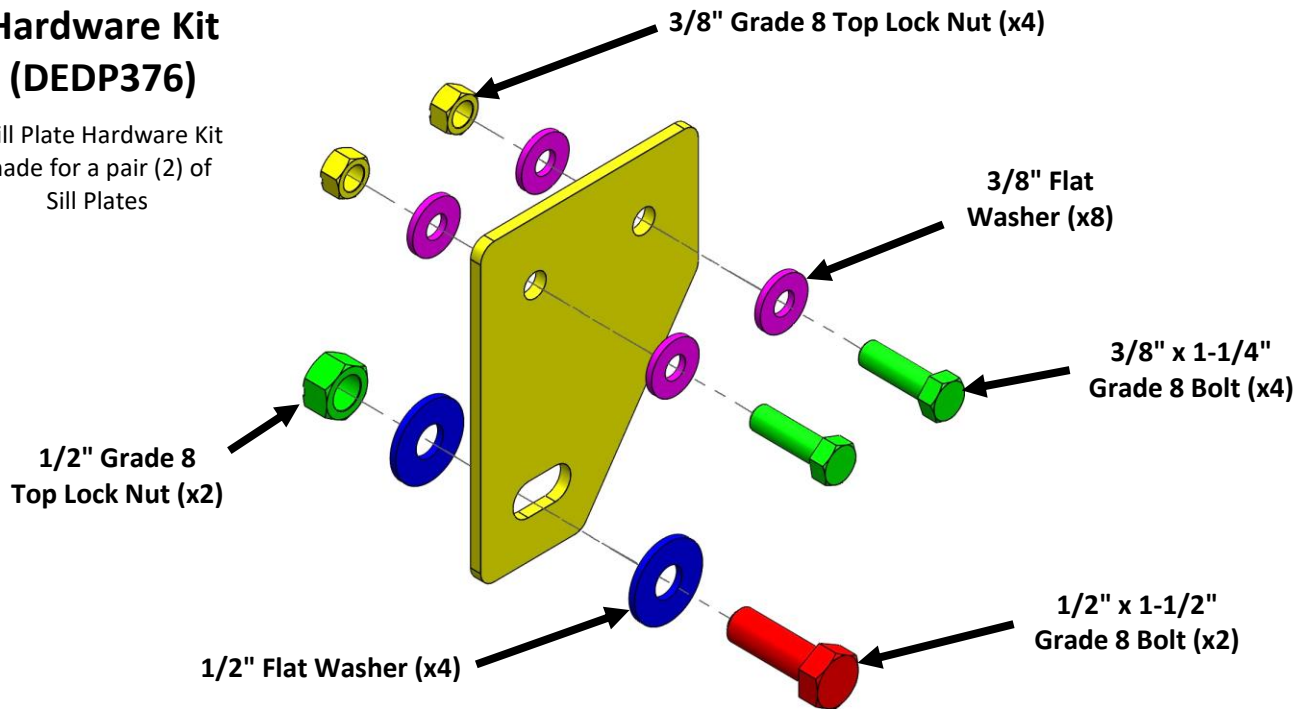

Figure 1-B

Subframe Chassis Bracket Hardware Kit (DEDP376)

*Subframe Chassis Bracket
Hardware Kit made for a pair (2)
of Subframe Chassis Brackets

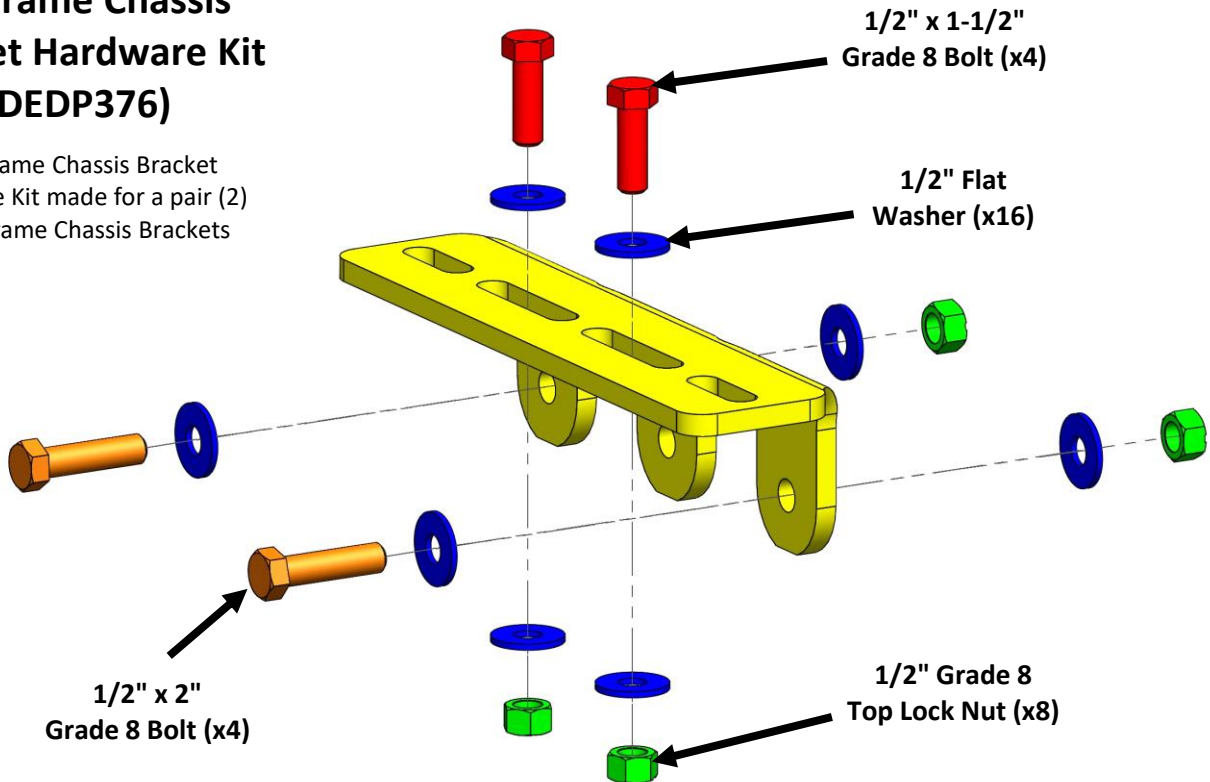

Figure 1-C

Frame Installation

Note: Installation identical for both sides.

Rear Subframe Attachment

Multiple methods are acceptable to attach the rear of the subframe to the vehicle chassis.

Option 1: Welded *Rear Hinge Angle*

The *Rear Hinge Angle* can be welded directly to the vehicle chassis.

Option 2: Bolted *Rear Hinge Angle*

The *Rear Hinge Angle* can be bolted to the vehicle chassis if welding is not desired, applicable, or an option. See *Appendix (p. 29)* for full size drilling template.

Drill Template Instructions

1) Cut out drill template (p. 27) and fold along dotted line, see *Fig. 1-A / 1-B*.

2) Measure and mark the top of chassis frame at the appropriate length from the end of chassis frame, see *Fig. 1-C*. For 11' frame length (CE), mark at $3/4"$. For 11'-3" frame length (CE), mark at $2-1/2"$.

3) Set template against the top and outer side of the chassis frame, see *Fig. 1-D / Fig. 1-E* (next page).

4) Line up the center mark of the circle closer to end of chassis with marking from Step 2, see *Fig. 1-D / 1-E*. Ensure the blank side of template is up flush against the outer side of chassis frame.

5) With the template in position, use a center punch to mark the hole centers.

6) Repeat *Step 2* to *Step 5* on the other side.

7) Check the distance from the center punch marks on one side of the vehicle frame to the other. Distance should be $31-1/8" \pm 1/8"$, see *Frame Installation: Fig. 4-A*.

6) Drill holes (4) using $17/32"$ drill.

NOTE: Prior to any drilling through frame, make sure any wiring, gas or brake lines are clear of drill path.

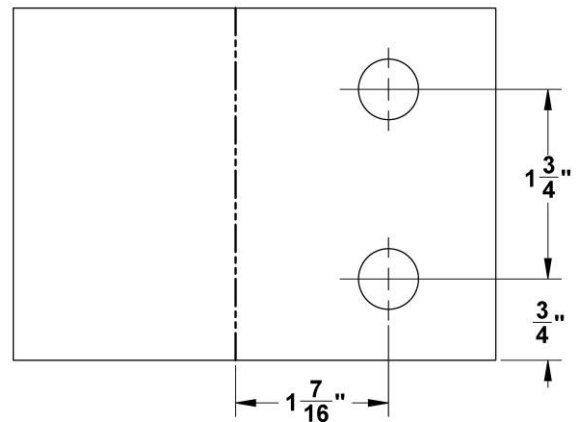

Figure 1-A: Drill Template (Not to Scale)

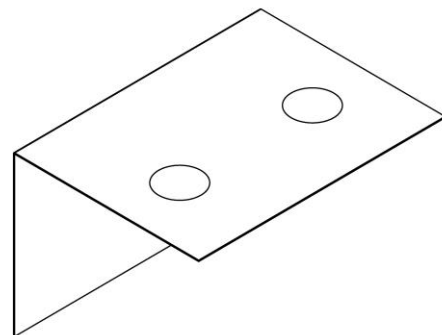

Figure 1-B: Drill Template (Not to Scale)

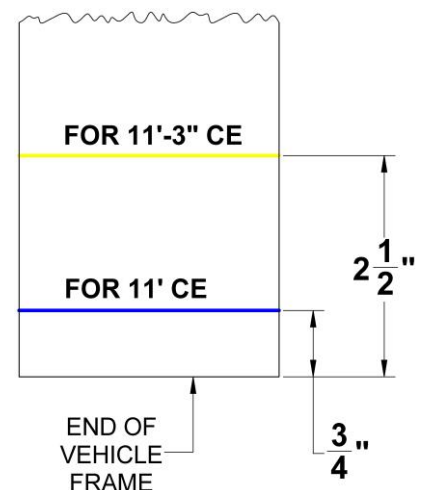

Figure 1-C

Frame Installation

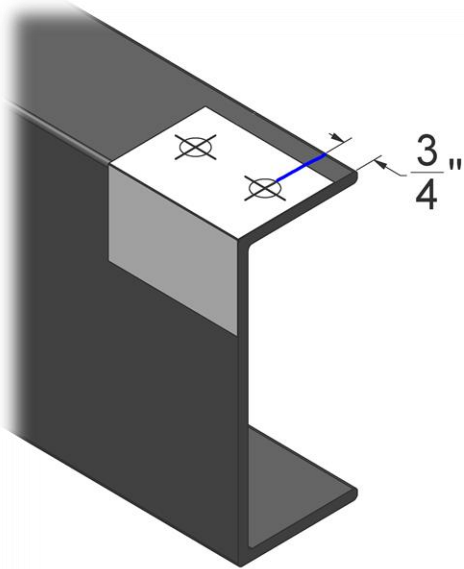

Figure 1-D

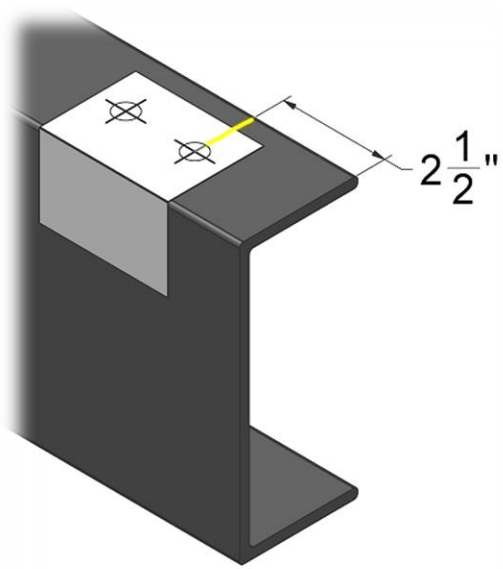

Figure 1-E

Option 3: Bolted Rear Hinge Angle with Sill Plate

The *Rear Hinge Angle* can be mounted with just one bolt if an obstruction prevents the use of both mounting holes. In this case, a rear *Sill Plate* **must** be used in conjunction with a single bolt at each *Rear Hinge Angle*, see *Fig. 2-B*. The rear *Sill Plate* is bolted to the chassis and can either be welded or bolted to the subframe. If welding to the subframe, the *Sill Plate* must be welded as close to the rear of the subframe as possible, and no more than 3" from *Rear Hinge Angle*, see *Fig. 2-A*. *Sill Plate* can be flipped to accommodate obstructions, but the 1/2" hole must remain on the bottom.

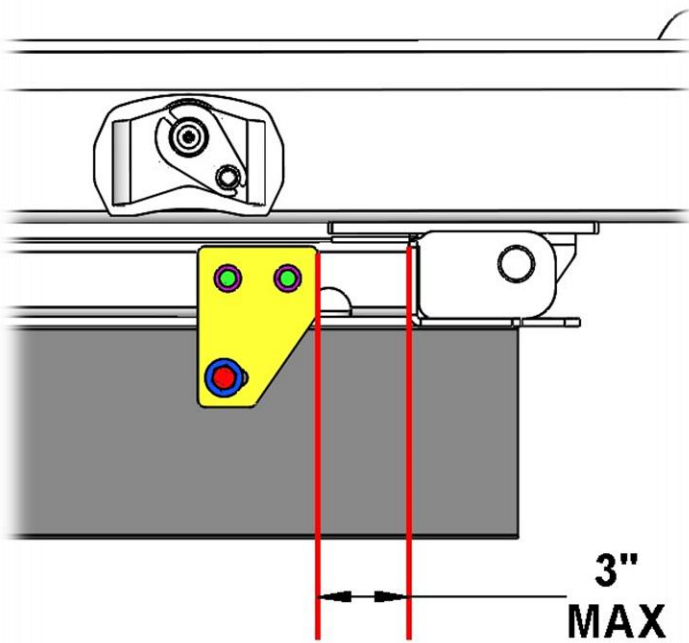

Figure 2-A

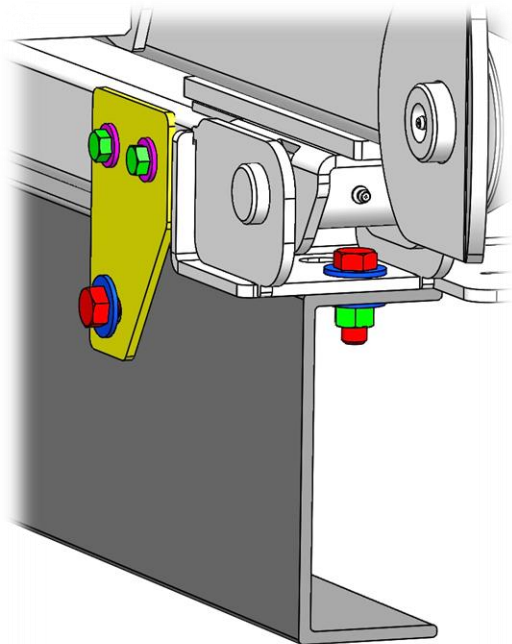

Figure 2-B

Frame Installation

Once a rear subframe attachment option is chosen, the installation can begin.

Step 1 - If *Option 1* was chosen for rear subframe attachment, then proceed to *Step 2*.
If using *Option 2* or *3*, then use *Drill Template Instructions* to drill the mounting holes.

Step 2 - If the vehicle has rivets where the *Hoist Mounting Pad* will sit: Place spacers (*Rivet Shims*) on vehicle chassis frame around rivets, see *Fig. 3-A*. Do not countersink the *Hoist Mounting Pad* that extends out from the subframe. **Do not remove rivet heads**. If rivets are the round style, they may be ground flush with the *Rivet Shim*. These plates are to be placed over the rivet heads for proper weight distribution.

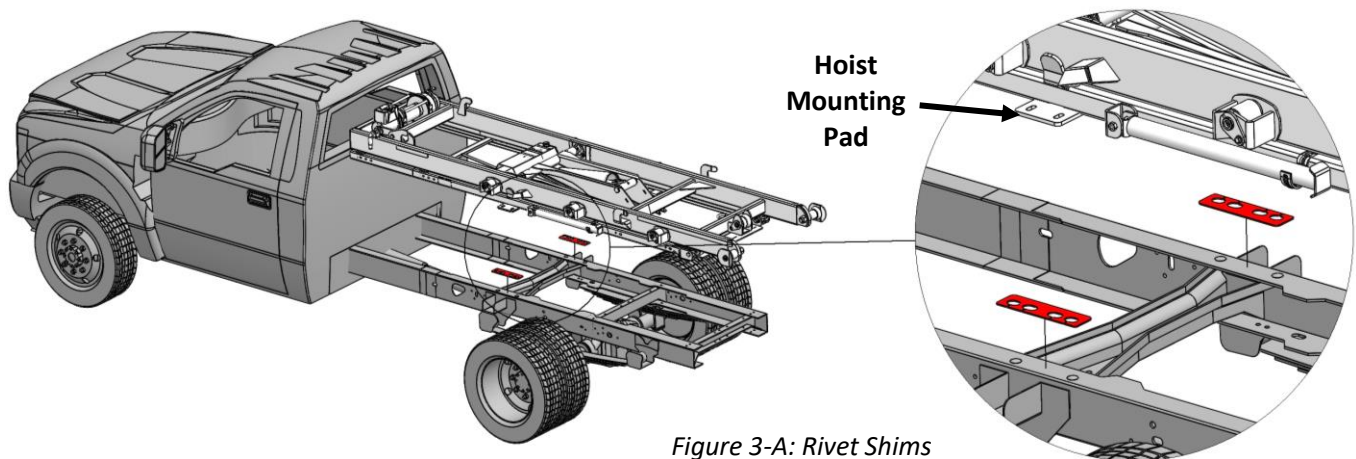

Figure 3-A: Rivet Shims

Step 3 - Set Swap Hogg frame on vehicle chassis frame.

If welding *Rear Hinge Angle*: Line up the appropriate edge of the *Rear Hinge Angle* (see *Fig. 4-A*) with the ends of chassis frame.

If bolting *Rear Hinge Angle*: Align hole(s) of rear hinge with hole(s) drilled in chassis.

Center *Rear Hinge Angle* on chassis width, making sure there is proper cab clearance and the entire subframe is centered on the chassis.

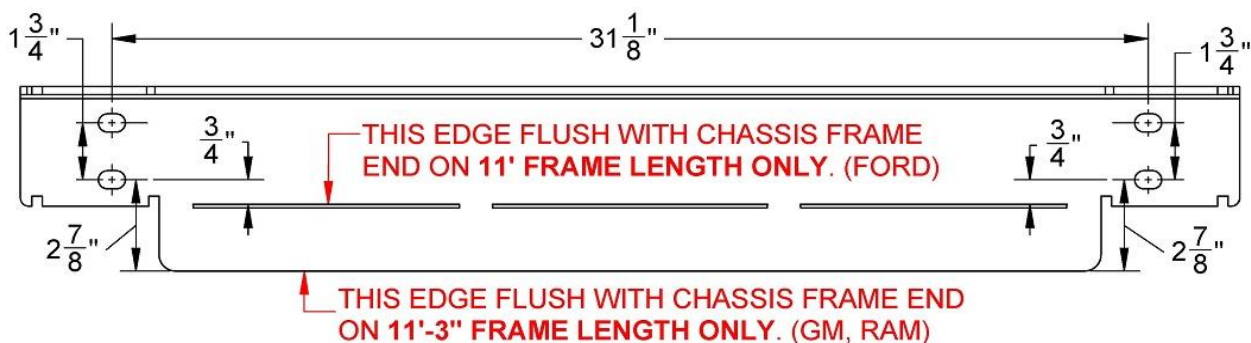

Figure 4-A: Rear Hinge Angle Dimensions

Frame Installation

Step 4 - Attach Rear Hinge Angle.

Welding Rear Hinge Angle: Tack weld Rear Hinge Angle to chassis frame. **DO NOT WELD TO CHASSIS FRAME ANYWHERE IN FRONT OF THE REAR SPRING HANGERS.**

Bolting Rear Hinge Angle: Temporarily clamp subframe in place and remove 1" hinge pins. Lift up the rear of the Swap Hogg top frame enough to put hardware in place. Install Rear Hinge Angle Hardware Kit (see Fig. 5-A), but do not fully tighten as slight repositioning may be required in later step. Bolts **must** be installed head up, as not to interfere with rear hinge operation. Lower top frame back onto subframe and reinstall 1" hinge pins.

Note: If installing on an 11' chassis frame, there may be an overhang from the Filler Bar (see Fig. 5-B) coming off the Rear Hinge Angle. You may cut this off, or leave in place as an overhang to protect hitch plate.

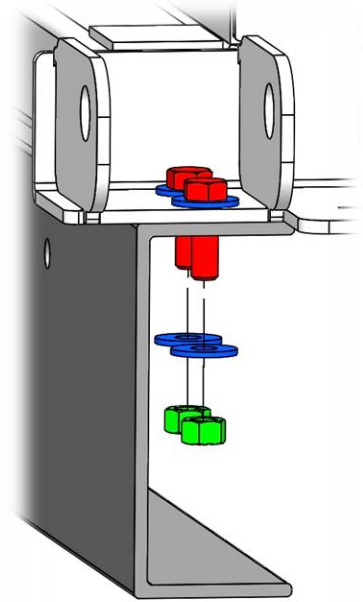

Figure 5-A: Bolted Hinge Angle



Figure 5-B: Rear Hinge Angle Filler Bar

Step 5 - Attach Subframe Chassis Bracket to subframe.

Once Swap Hogg frame is positioned correctly, position Subframe Chassis Brackets to Hoist Mounting Pads protruding from the subframe, see Fig. 6-A. The chassis brackets have three tabs for multiple brands. One tab may have to be cut off for clearance. EXAMPLE: Most GM and Ford applications will require the center tab to be removed, and Ram trucks may need to have the forward tab removed on both sides to clear front spring perch hanger.

Attach bracket to subframe, as shown in Fig. 6-A, using the Subframe Chassis Bracket Hardware Kit. Use the 1-1/2" long bolts for this step (the 2" bolts from this kit are used to attach bracket to chassis frame). Tighten bolts just enough to hold brackets in place, making sure that they are tight against the chassis frame for drilling (slight repositioning may be required in later step).

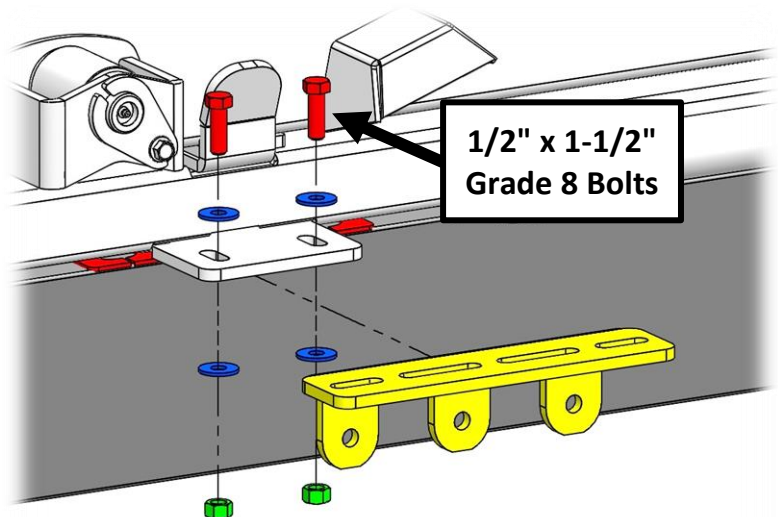

Figure 6-A: Subframe Chassis Bracket with Hardware

Frame Installation

Step 6 - Attach *Sill Plates* to subframe.

Sill Plates can either be welded to the subframe or bolted using the *Sill Plate Hardware Kit*. Any *Sill Plate* can be flipped to accommodate obstructions, but 1/2" hole must remain on the bottom. **All** installations will require at least one set of front *Sill Plates*. Installations that only utilize one bolt to secure the *Rear Hinge Angle* **must** use a set of rear *Sill Plates*, see *Rear Subframe Attachment: Option 3*. A third set of *Sill Plates* is provided and use is recommended, but not required.

Welding *Sill Plates*: It is recommended that the front *Sill Plates* be attached as close as possible to the front of the subframe, but can be placed anywhere in the area shown in *Fig. 7-A* to accommodate for obstructions. See *Rear Subframe Attachment: Option 3* for rear *Sill Plate* location. If utilizing a third set of *Sill Plates*, place them between the front *Sill Plates* and the *Subframe Chassis Brackets*. Weld *Sill Plates* in place making sure they are flush against the chassis frame for drilling.

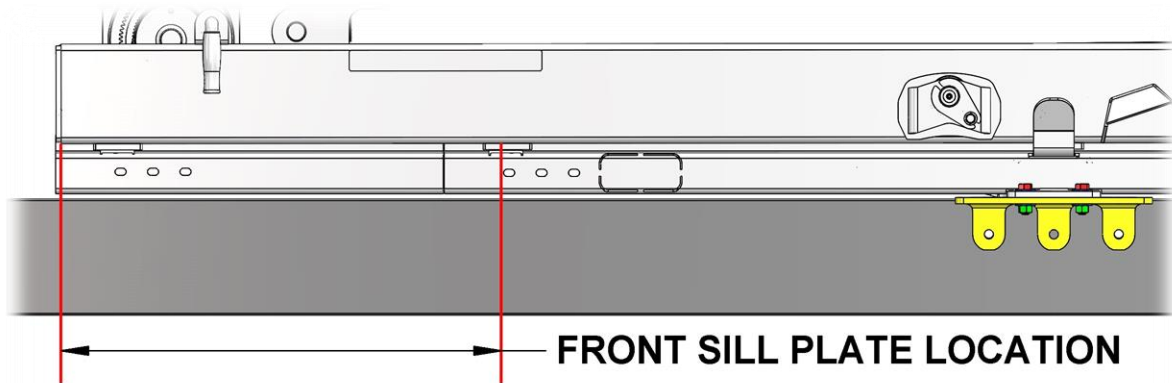

Figure 7-A: Front Sill Plate Location

Bolting *Sill Plates*: *Sill Plates* are bolted to the subframe using the provided 3/8" hardware from *Sill Plate Hardware Kit*, see *Fig. 7-B / 7-C*. Front *Sill Plates* are attached to the subframe using the frontmost set of slotted holes. Either two of the three holes can be used. Rear *Sill Plates* are attached to the subframe at the rear most set of holes. If the third set of *Sill Plates* is being utilized, they can be attached using the set of holes between the front set of *Sill Plates* and the *Subframe Chassis Brackets*. Insert hardware and tighten bolts just enough to hold *Sill Plates* in place, making sure that they are tight against chassis frame for drilling (slight repositioning may be required in later step).

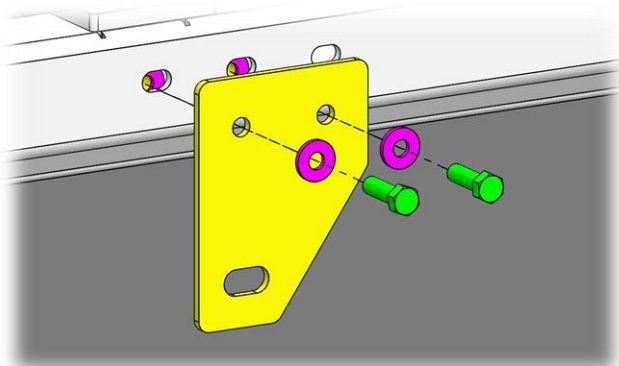

Figure 7-B: Sill Plate Hardware

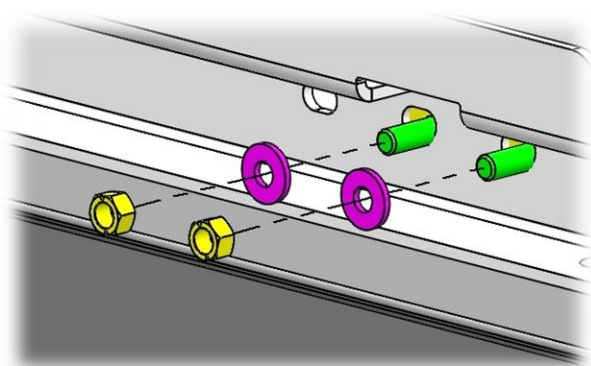

Figure 7-C: Sill Plate Hardware

Frame Installation

Step 7 - Drill holes for *Subframe Chassis Brackets* and *Sill Plates*.

Use the 1/2" holes of the *Subframe Chassis Brackets* and the 1/2" slots of the *Sill Plates* as guides to drill 17/32" holes in the vehicle chassis frame, see Fig. 8-A. The *Subframe Chassis Brackets* each require 2 holes for mounting and each *Sill Plate* requires one. **Prior to any drilling through frame, make sure any wiring, gas or brake lines are clear of drill path.**

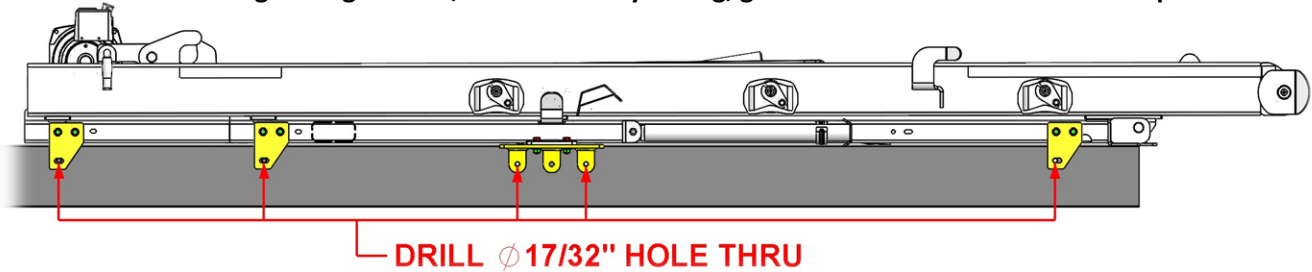

Figure 8-A: Chassis Frame Drill Locations

Step 8 - Attach *Subframe Chassis Bracket* and *Sill Plates* to vehicle chassis frame using 1/2" hardware provided (1/2" x 1-1/2" bolts for *Sill Plates*, 1/2" x 2" bolts for *Subframe Chassis Brackets*), see Fig. 9-A. Install all hardware loosely before fully torquing any bolts (slight repositioning may be required to align holes).

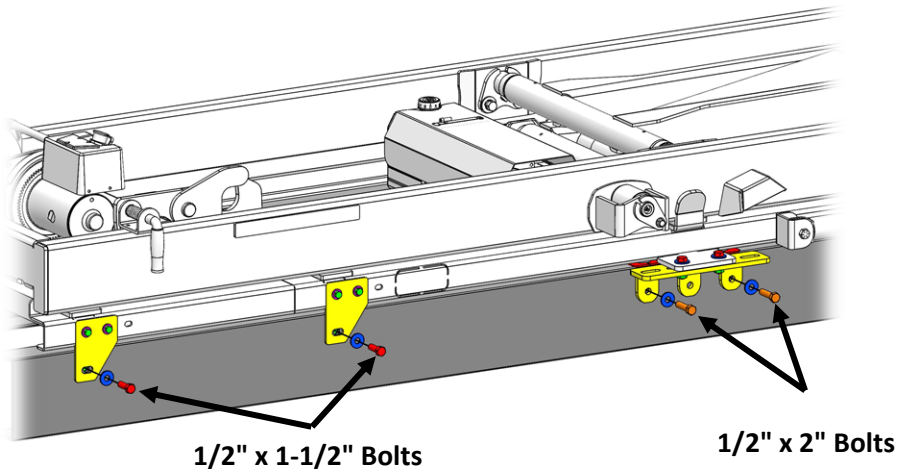

Figure 9-A: Chassis Hardware

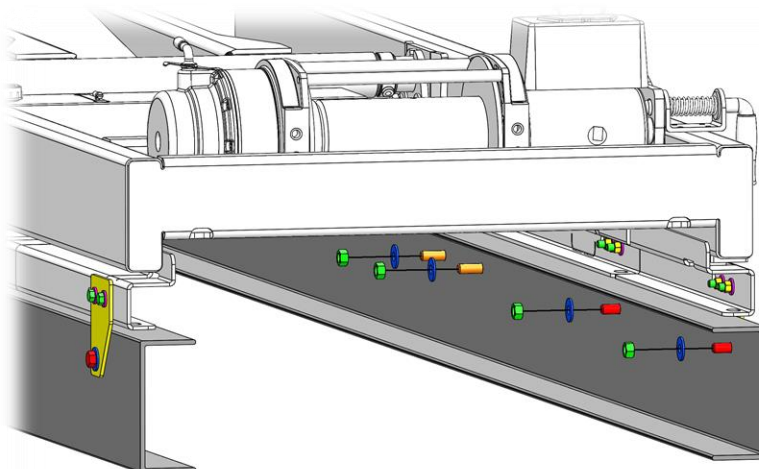

Figure 9-B: Chassis Hardware

Frame Installation

Step 9 - Properly torque all bolts, see *Torque Table (Fig. 10-A)* for proper values.



Size	Grade 2 Torque	Grade 5 Torque	Grade 8 Torque
			
1/4-20	3-4 lb-ft	6-7 lb-ft	10-11 lb-ft
1/4-28	4-5 lb-ft	8-9 lb-ft	11-12 lb-ft
5/16-18	8-9 lb-ft	14-15 lb-ft	21-22 lb-ft
5/16-24	9-10 lb-ft	15-16 lb-ft	21-22 lb-ft
3/8-16	17-18 lb-ft	24-26 lb-ft	37-40 lb-ft
3/8-24	19-20 lb-ft	28-30 lb-ft	40-43 lb-ft
1/2-13	38-42 lb-ft	60-65 lb-ft	90-100 lb-ft
1/2-20	43-47 lb-ft	70-75 lb-ft	95-105 lb-ft
5/8-11	75-80 lb-ft	122-130 lb-ft	180-190 lb-ft
5/8-18	85-90 lb-ft	145-150 lb-ft	200-210 lb-ft
3/4-10	132-140 lb-ft	220-230 lb-ft	315-330 lb-ft
3/4-16	152-160 lb-ft	250-260 lb-ft	355-370 lb-ft

Figure 10-A: Torque Table

Step 10 - If *Rear Hinge Angle* was bolted, Swap Hogg frame installation is complete. If *Rear Hinge Angle* was tack welded, finish welding rear hinge angle to chassis, see *Fig. 11-A*. **Ensure all gasoline lines, tanks, fittings, and electrical components are protected from damage, heat and sparks. Failure to protect fuel system may result in gasoline being ignited, which may result in unit, property, or vehicle damage, as well as serious injury or death.**

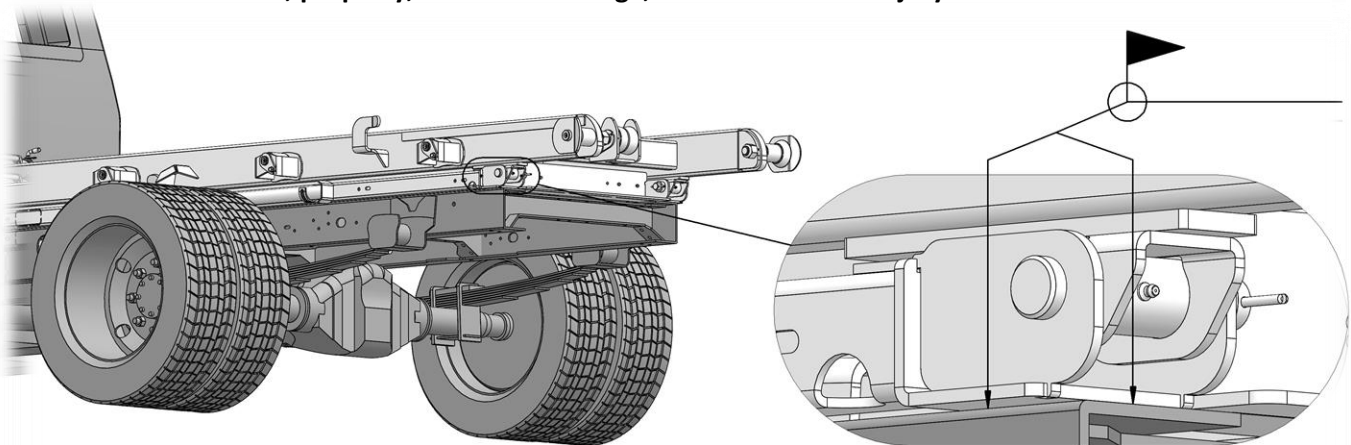

Figure 11-A: RHA Weld

Swap Hogg frame installation is now complete.

Electric Installation

- Step 1** - Disconnect the positive and negative battery cable from both vehicle batteries.
- Step 2** - Route and secure the power (red) and ground (black) cables from the Swap Hogg pump to the battery. Do not connect cables to battery at this step.
- Step 3** - Mount *Fuse Holder* within the engine bay, preferably somewhere close to the battery.
- Step 4** - Loosen nut on the *Fuse Holder* terminals and place the *Fuse* into the *Fuse Holder*.
- Step 5** - Connect power cable from Swap Hogg to one terminal of *Fuse Holder* . Connect *Battery Cable (DEDP506)* to other terminal of *Fuse Holder*, see Fig. 1-A.
- Step 6** - Tighten nuts on *Fuse Holder* terminals.
- Step 7** - Connect *Pendant Extension Cord (DEDP418)* to the 6-pin cord coming off the Swap Hogg pump.
- Step 8** - Route the *Pendant Extension Cord (DEDP418)* from the Swap Hogg to the desired location inside of the vehicle cab. Secure the cable.
- Step 9** - Connect *Pendant Extension Cord (DEDP418)* to *Control Pendant (DEDP416)*.
- Step 10** - Connect the ground cable from the Swap Hogg to the negative battery terminal. **If a vehicle chassis ground is used, or the provided fuse is not installed, warranty will be voided.**
- Step 11** - Connect *Fuse to Battery Cable (DEDP506)* to the positive battery terminal.
- Step 12** - Reconnect any cables removed in *Step 1*.
- Step 13** - Electric installation is complete.

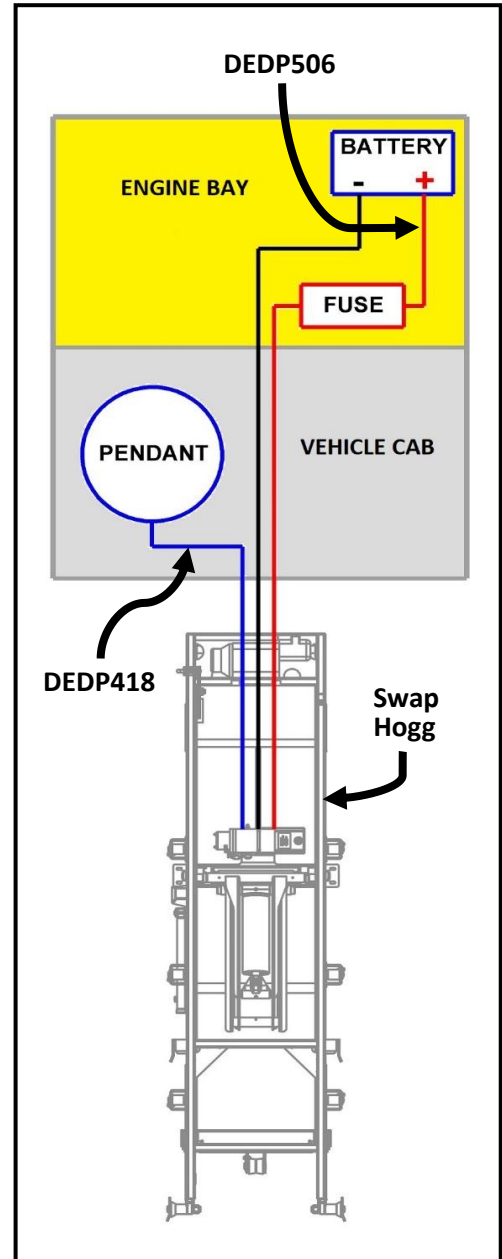

Figure 1-A

Winch Cable Installation

*For complete winch operation and techniques go to: <https://www.warn.com/series-15-electric-12v-winch-15000-lb-66032>

Anchoring Cable on Drum

CAUTION! *Always install cable in the direction specified on the drum rotation label, or brake will not function.*

CAUTION! *Always maintain a minimum of five (5) wraps of cable on the drum. Fewer wraps may cause the end of the cable to pull free of the drum and drop the load.*

- Step 1 -** Loosen set screw enough to insert cable (DEDR152B) through anchor slot.
- Step 2 -** Insert cable through slot in as shown.
- Step 3 -** Tighten set screw, torque to 12-15 ft-lbs.
- Step 4 -** With end of rope securely installed, carefully wind rope evenly onto drum. Keep rope under tension at all times, see *Spooling in Cable* for more detailed directions.
- Step 5 -** Lubricate cable while winding winch in.
- Step 6 -** Once cable is fully spooled in, clean up any excess lubricant.

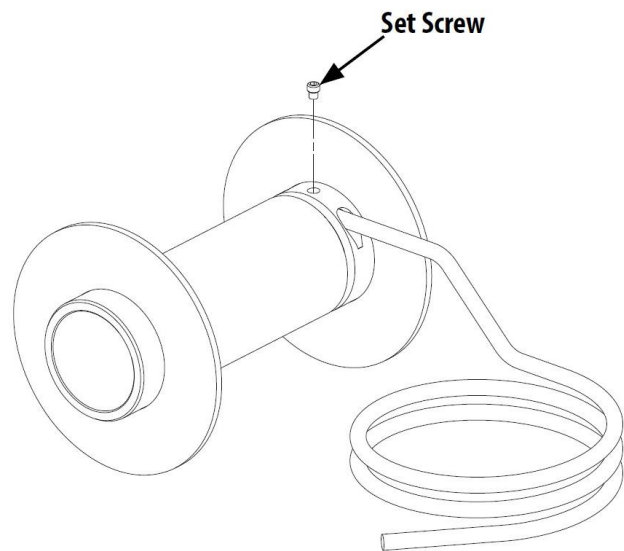

Figure 1-A

Spooling in Cable

Spooling with an Assistant: Have the assistant hold the hook putting as much constant tension on the winch cable as possible. While keeping tension, the assistant should walk toward the winch while you operate the control switch spooling in the winch cable.

Spooling Alone: Arrange the winch cable to be spooled so it will not kink or tangle when spooled. Be sure any winch cable on the drum is tightly and evenly layered. Spool enough winch cable to complete the next full layer on the drum. Tighten and straighten the layer. Repeat until cable is fully spooled in.

Swap Hogg Optional Installations

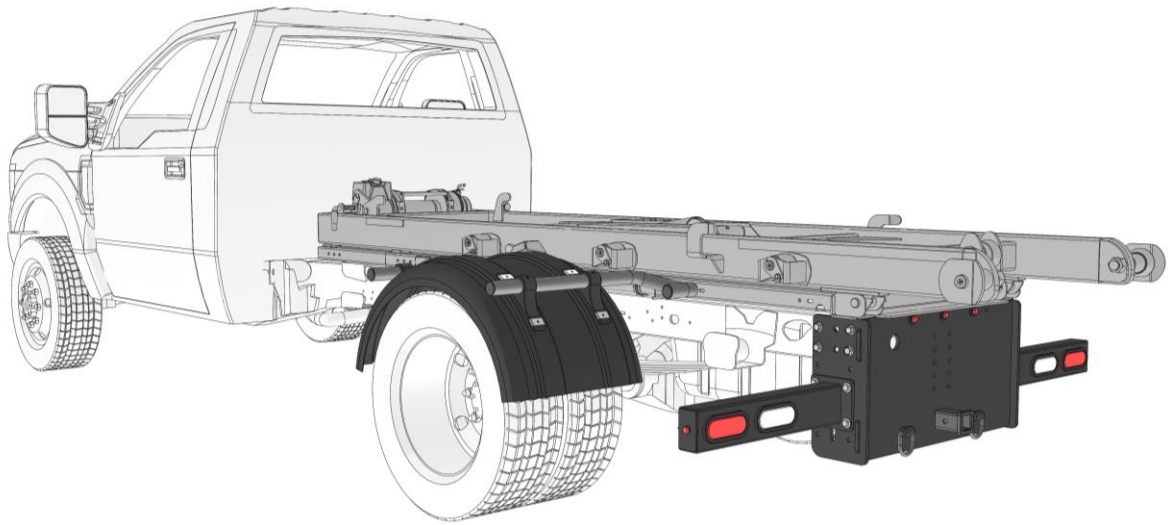

Poly Fender Wheel Kit

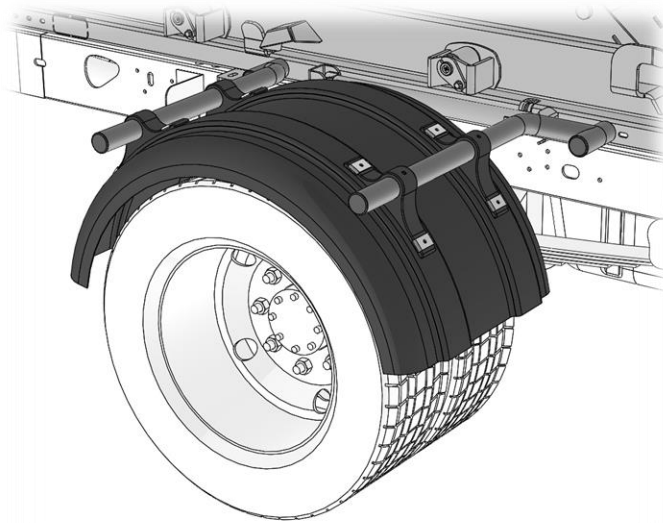

Hitch Plate Bumper

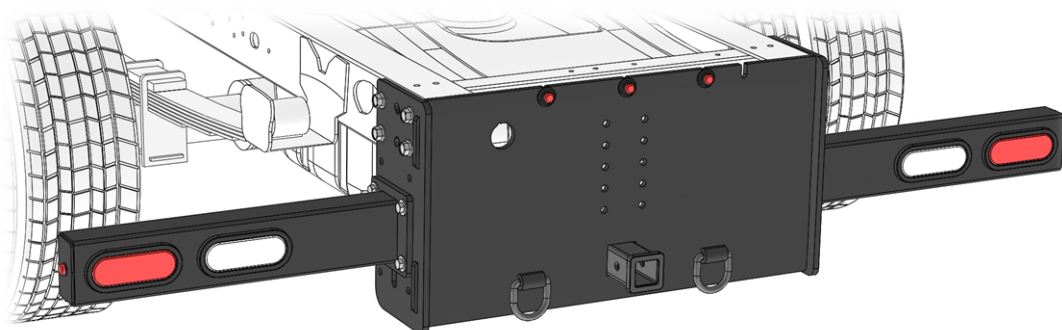

Fender Installation

- Step 1 -** Set fender over tire.
- Step 2 -** Place spacers (2x4 or 2x6 blocks work well) between the tire and fender to achieve desired clearance, see Fig. 1-A. SAE recommends a minimum clearance of 3". Some vehicles will require more clearance depending on the amount the suspension drops under a full load.

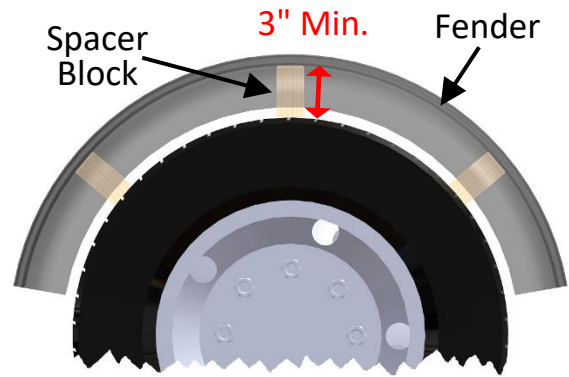

Figure 1-A

- Step 3 -** Slide hanger brackets onto mounting arm.
- Step 4 -** Position mounting arm so that:
- ✓ It can be mounted to either the Swap Hogg subframe or the frame of the vehicle.
 - ✓ It will not obstruct or interfere with any other parts on the vehicle.
 - ✓ Hanger brackets sit flush on the protrusions of the fender, see Fig. 2-A.
 - ✓ Bottom edge of hanger brackets sit at least 10" up from the bottom of the fender.

- Step 5 -** Mounting arms can be attached to the vehicle using existing holes or new holes can be drilled. If using new holes, mark the desired locations and drill out the holes. **NOTE:** If mounting to vehicle frame, be sure to follow vehicle manufacture's procedures for drilling through frame.

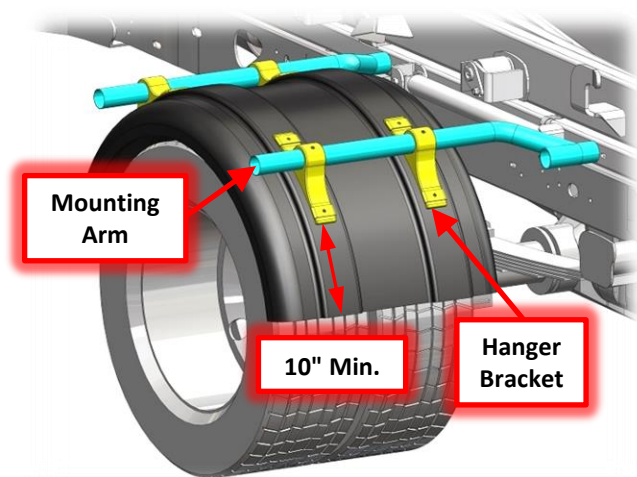

Figure 2-A

- Step 6 -** Attach mounting arms to vehicle using provided hardware. Only tighten bolts enough to keep mounting arms in place (slight repositioning may be required in later step.)
- Step 7 -** Position the hanger brackets so they are flush and centered on the protruding faces.
- Step 8 -** Mark the hole locations on the fender.
- Step 9 -** Take the fender off the wheel and drill holes for hanger brackets.
- Step 10 -** Position fender over wheel and attach to hanger brackets using the provided hardware.
- Step 11 -** Properly torque all nuts, bolts, and set screws.
- Step 12 -** Insert end caps into mounting arms. Fender installation is now complete.

Hitch Plate Installation

Hitch plate can be mounted to the vehicle frame via welding, mounting with hardware, or using a combination of both methods. Regardless of the method chosen, it is recommended that the hitch plate be installed before the Swap Hogg frame. Installing the hitch plate before the Swap Hogg frame will allow for better access to the vehicle frame. In some cases, bolting the hitch plate may not be an option if the Swap Hogg frame is already installed and can't be removed.

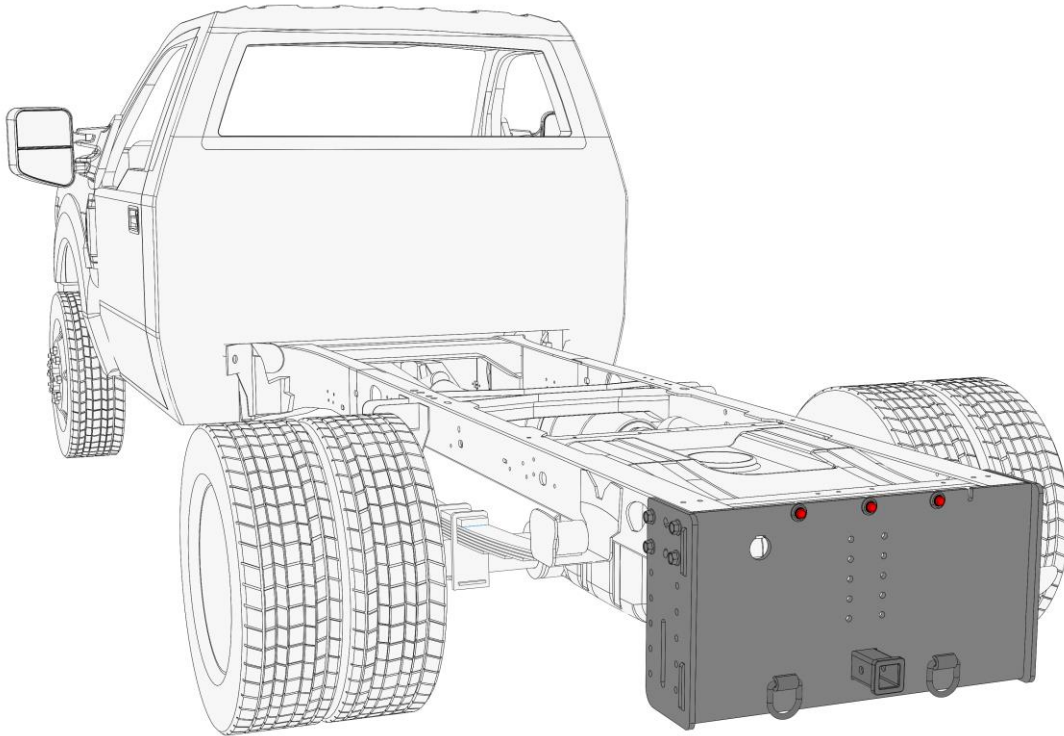

Figure 1-A

Hitch Plate Positioning:

- ✓ Set the hitch plate against the end of the vehicle chassis frame, see Fig. 2-A
- ✓ Set the top of the hitch plate flush with the top of vehicle chassis frame, see Fig. 2-B
- ✓ Set hitch plate square to vehicle chassis frame, see Fig. 2-A & 2-B

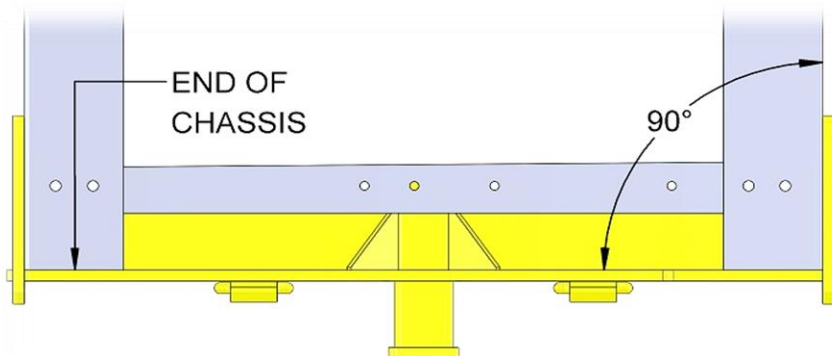

Figure 2-A

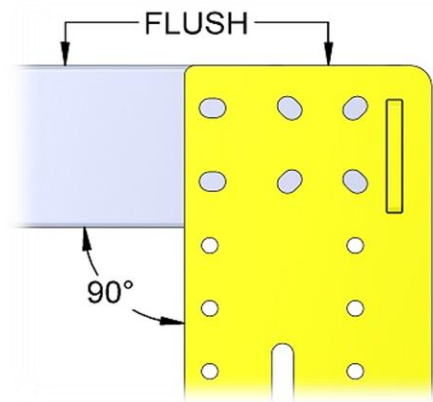

Figure 2-B

Hitch Plate Installation

Welding to Chassis

The hitch plate can be welded directly to vehicle chassis frame. Weld the side plates to the outside of the vehicle chassis frame, see *Fig. 3-A* (side plates shown transparent to show weld joints). Weld the center plate of the hitch plate to the ends of the vehicle chassis frame, see *Fig. 3-B* (center plate shown transparent to show weld joints).

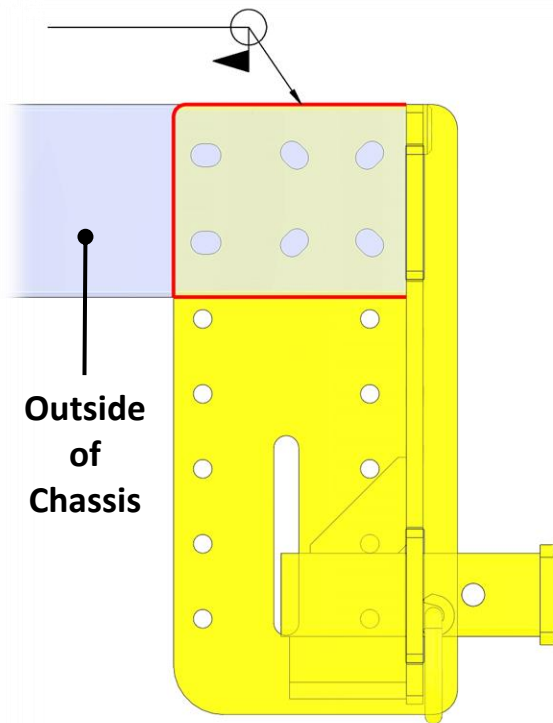

Figure 3-A

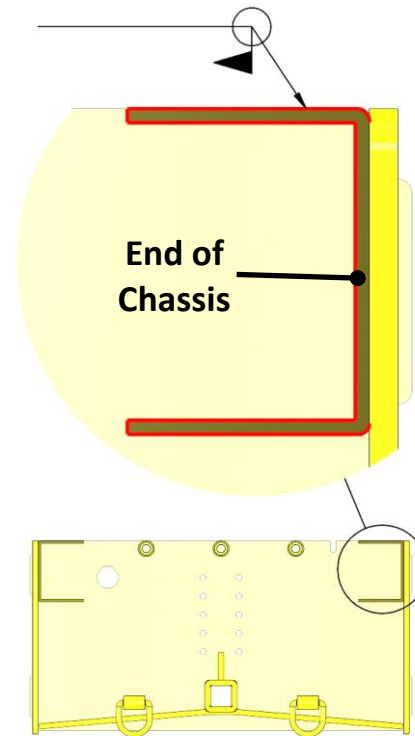

Figure 3-B

Bolting to Chassis

The hitch plate can be mounted to chassis using existing holes in the frame, and/or new holes can be drilled for mounting. Regardless of the combination of new/existing holes used, **hitch plate must be secured with at least 4 bolts on each side**. When choosing which slots of the hitch plate to use, try to select the most dispersed set possible (ideally the 4 corner slots), see *Fig. 4-A* (center plate shown transparent to show hardware).

Step 1 - Mark and drill holes if necessary.

Step 2 - Attach hitch plate with provided hardware.

Step 3 - Properly torque nuts & bolts, see torque chart.

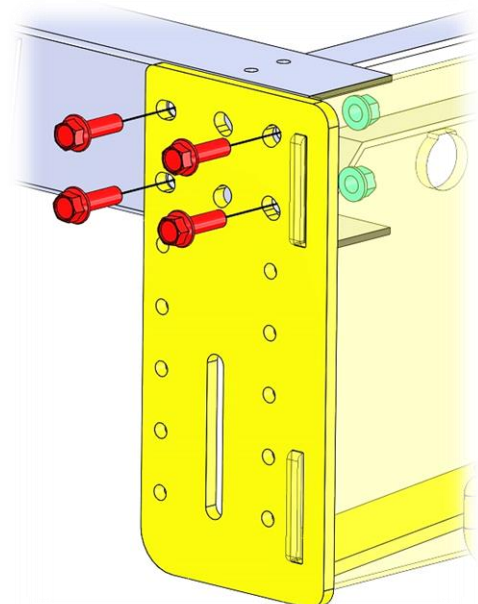

Figure 4-A

Light Bar Installation

Installation of the bumper light bars will comprise: mounting the light bars to the bumper, running the wire harness to the light holes, installing the lights, and wiring the wire harness into the vehicle's wiring.

Step 1 - The bumper has 3 sets of holes which allow the light bars to be mounted at various heights. Using the provided hardware, mount the light bars to the bumper with the light holes facing the rear of the vehicle, see Fig. 1-A (light bar transparent to show hardware). Properly torque all nuts and bolts, see *Torque Chart*.

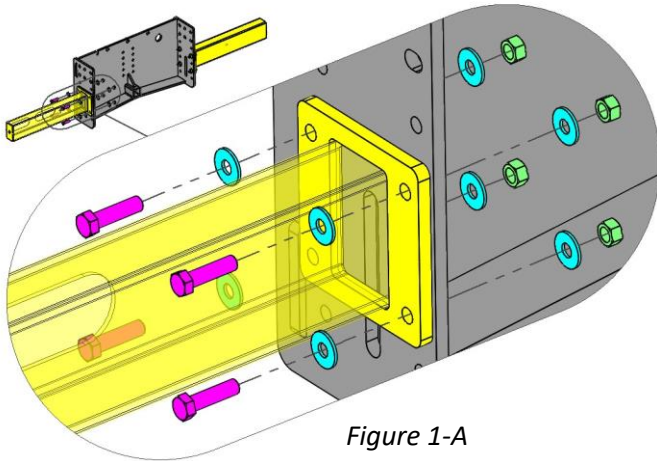

Figure 1-A

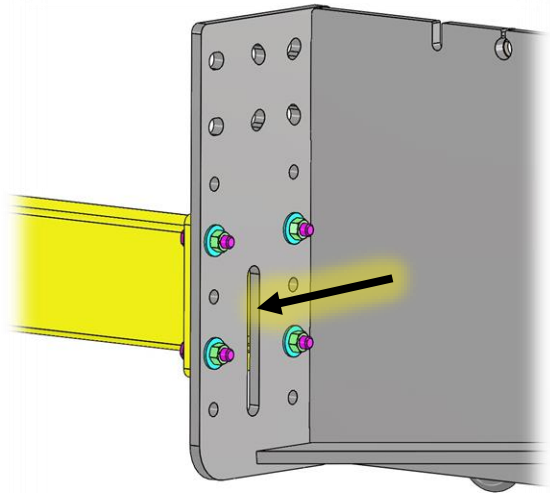

Figure 1-B

Step 2 - The sides of the bumper have slots to route wires to the light bars, see Fig. 1-B. The 48" wire bundle goes to the driver side light bar, the 70" wire bundle goes to the passenger side light bar, and the 22" wire bundle goes to the bumper hitch plate, see Fig. 2-A. Route the wires to their respective locations.

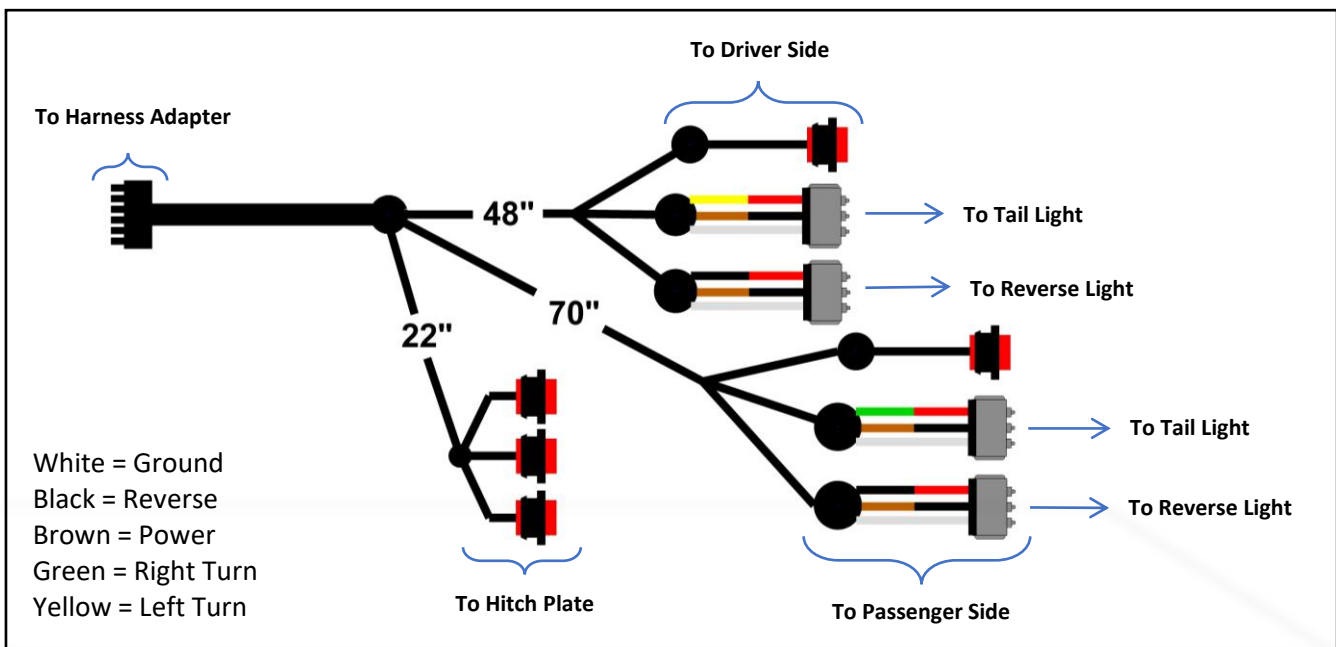
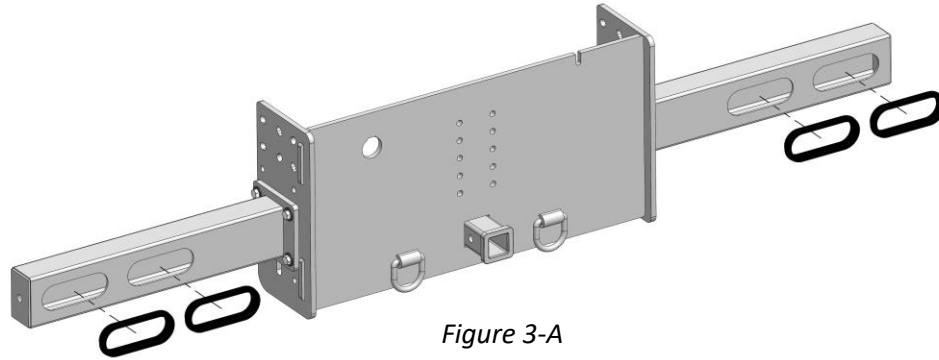

Figure 2-A

Light Bar Installation

Step 3 - Insert grommets for the 4 oval lights, see *Fig. 3-A*.



Step 4 - Pull each wire connector out through its corresponding light hole and connect to lights. Red lights go in outer holes and clear lights go in inner holes, see *Fig 4-A*.

Step 5 - Set lights into grommets.

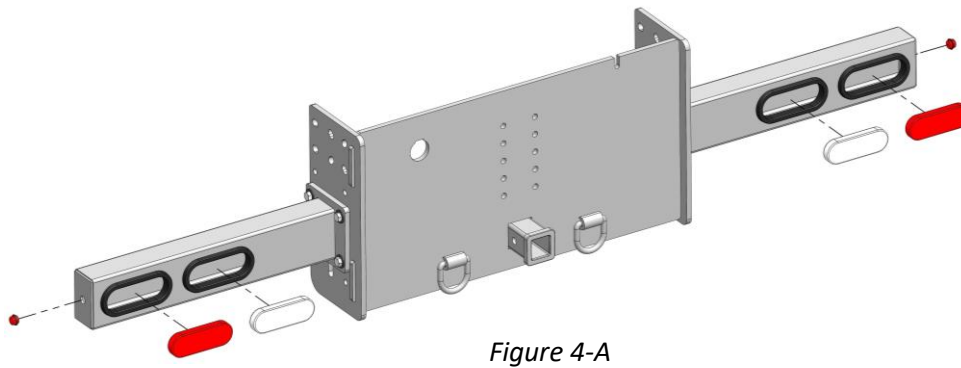

Step 6 - Connect the bumper wiring harness to the harness adapter, see *Fig 5-A* for adapter.



Vehicle Manufacturer	Model Year	Part #
Ford	1999 to Current	DEDP369
GM	Previous to 2016	DEDP371
GM	2016 to Current	DEDP373
Ram	1999 to Current	DEDP374

Figure 5-A

Step 7 - Connect the harness adapter to the vehicle's plug in.

Appendix

Torque Table

Size	Grade 2 Torque	Grade 5 Torque	Grade 8 Torque
			
1/4-20	3-4 lb-ft	6-7 lb-ft	10-11 lb-ft
1/4-28	4-5 lb-ft	8-9 lb-ft	11-12 lb-ft
5/16-18	8-9 lb-ft	14-15 lb-ft	21-22 lb-ft
5/16-24	9-10 lb-ft	15-16 lb-ft	21-22 lb-ft
3/8-16	17-18 lb-ft	24-26 lb-ft	37-40 lb-ft
3/8-24	19-20 lb-ft	28-30 lb-ft	40-43 lb-ft
1/2-13	38-42 lb-ft	60-65 lb-ft	90-100 lb-ft
1/2-20	43-47 lb-ft	70-75 lb-ft	95-105 lb-ft
5/8-11	75-80 lb-ft	122-130 lb-ft	180-190 lb-ft
5/8-18	85-90 lb-ft	145-150 lb-ft	200-210 lb-ft
3/4-10	132-140 lb-ft	220-230 lb-ft	315-330 lb-ft
3/4-16	152-160 lb-ft	250-260 lb-ft	355-370 lb-ft

Parts & Components

Hoist System Parts & Components

Part Name	Part #	Description
Spring Latch	DEDR108	3/4" Spring latch for body lock
Body Lock Plate	DEDM870	Plate for locking body while transporting and dumping
Scissor Hoist	DEHP615	Scissor hoist, w/ 6" bore x 15" stroke cylinder
Hydraulic Pump	TPH108	Hydraulic pump, power up/power down, 1.5 gal tank
Electric Winch	DEDR148	15k electric winch
Tensioner Plate	DEDR149	Tensioner plate for 15k electric winch
Winch Cable	DEDR152B	25' winch cable with spring latch hook
Winch Stop Switch	DEDP424A	Switch to stop winch when fully drawn in
Side Roller Shaft	DEDM860	Shaft for side rollers
Side Roller	DEDR166	2.5" polyurethane roller with steel DOM insert
Rear Guide Roller Shaft	DEDM844	Shaft and guide plate for rear guide roller with 1.25" lock nut
Rear Guide Roller	DEDR144	Roller to guide and align body as it initially rolls up frame
Center Roller Shaft	DEDM856	Shaft for center roller
Center Roller	DEDR122	Roller for winch cable to ride up/down
Pump Cover	DEDM876	Stainless steel cover for hydraulic pump
Upper Lift Shaft	DEDM540	Shaft connecting the hoist and top frame
Battery Cable Set	DEDP505	18' positive and negative battery cables for Swap Hogg frame
Subframe Chassis Brackets	DEDM436	Pair (2) of brackets to connect subframe mounting pad to vehicle frame
Sill Plate Bracket	DEDM550	Bracket to connect the front and back of subframe to the vehicle frame
Rivet Shim	DEDM444S	Stainless steel spacer between subframe and vehicle frame
Battery Cable Fuse	DEDP426	600A fast acting fuse
Control Pendant	DEDP416	4 button control pendant for winch and hoist
Pendant Extension Cord	DEDP418	15' 6 wire extension to connect pendant to pump
Winch Controls Wire Harness	DEDR872	Wire harness for Swap Hogg winch controls

Optional Parts & Components

Part Name	Part #	Description
Poly Fender Kit	Fender Kit	Includes 2 fenders & 2 mounting kits [DEDP450 (x2), DEDP452 (x2)]
Poly Fender	DEDP452	Single poly fender for 18" to 19.5" wheel
Fender Mounting Kit	DEDP450	Mounting kit for single poly fender
Hitch Plate	Hitch Plate	Hitch plate bumper for 34" wide frame, includes mounting hardware (DEDR304)
Hitch Plate Mounting Kit	DEDR304	Hardware to mount hitch plate (included with hitch plate)
Bumper Light Bars	Hitch Plate Tubes	Bumper light bar tubes for hitch plate, includes assembly hardware (DEDR306)
Light Bar Mounting Kit	DEDR306	Hardware to mount bumper tubes to hitch plate.
Bumper Harness Kit	Hitch Bumper Harness	Bumper light kit, includes tail lights (x2), back up lights (x2), oval grommets (x4), license plate bracket (x1), and bumper wire harness (x1)
Bumper Wire Harness	DEDP508	Wire harness for bumper tube light kit
Tail Light	TPE104	Red LED tail light, 6" oval, grommet mounted
Back Up Light	DEDP290	Clear LED tail light, 6" oval, grommet mounted
Light Grommet	TPE173A	Grommet for 6" oval lights (tail lights & back up light)
License Plate Bracket	DEDP264	License plate bracket with LED license plate light
Ford Harness Adapter ('99-Current)	DEDP369	Bumper harness to vehicle adapter for 1999 and newer Ford chassis cab trucks
Ram Harness Adapter ('99-Current)	DEDP374	Bumper harness to vehicle adapter for 1999 and newer Ram chassis cab trucks
GM Harness Adapter ('16-Current)	DEDP373	Bumper harness to vehicle adapter for 2016 and newer GM chassis cab trucks
GM Harness Adapter (Pre '16)	DEDP371	Bumper harness to vehicle adapter for 2015 and older GM chassis cab trucks

Parts Diagram

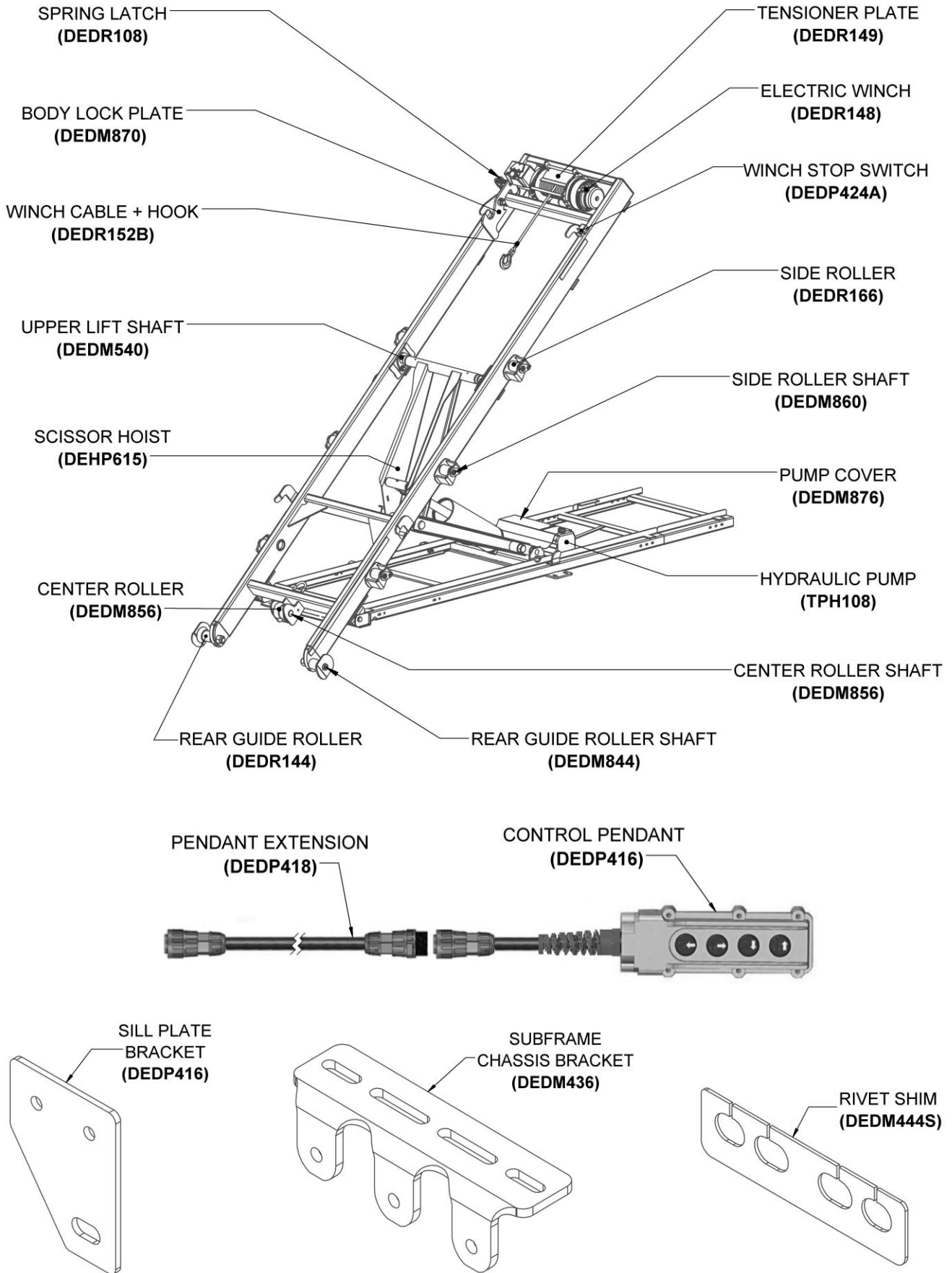

Troubleshooting

Problem	Probable Cause	Corrective Action
Hoist and/or pump inoperative.	Bad control pendant connection	Check pendant for loose connections or damage
	Bad power connection	Check for loose connections, damaged wires, or blown fuse
	Weak battery	Ensure batteries meet system requirements and is properly charged
Hoist won't go up	Low hydraulic fluid	Fill tank to proper level and check system for leaks
	Pump pressure is set too low	Contact manufacturer for correct pump settings
	Defective up coil	Replace coil
Hoist won't go down	Low hydraulic fluid	Fill tank to proper level and check system for leaks
	Damaged/broken hydraulic line	Repair or replace hydraulic line
	Body lock engaged before top frame is fully lowered	Disengage body lock
	Defective down coil	Replace coil
Hydraulic tank leaks	Clogged breather cap	Remove and clean breather cap
	Stuck valve	Remove valve and check for obstructions
Winch won't move in or out	Defective winch motor	Replace motor
	Bad cable connections	Ensure all cable connections are secure
Winch moves in the wrong direction	Winch wires are reversed	Attach wire to proper locations
	Cable spooled in the wrong direction	Unspool cable and respool in the correct direction
Winch won't pull in load	Load exceeds winch rating	Remove portion of the load to bring load weight within capacity
	Too much cable on drum	Remove excess cable
	Defective winch motor	Replace motor
	Broken gears in winch	Replace broken gears
Load won't release	Body lock engaged	Disengage body lock
Cable detaches from winch	Set screw not properly torqued	Torque set screw to proper value (see cable installation instructions)
	Inadequate amount of cable wraps on winch drum	Ensure that at least 5 cable wraps are maintained on winch drum
Winch overheats during operation	Load exceeds winch rating	Remove portion of the load to bring load weight within capacity
	Not giving enough cooling time between loads	Give at least 1 hour of cool down time between max loads
	Worn motor brushes	Replace motor